

Installation, Operation, and Maintenance Manual



Up-blast Centrifugal Utility Fan



Up-blast Centrifugal Fan



Down-blast Centrifugal Fan



Axial Fan

RECEIVING AND INSPECTION

Upon receiving unit, check for any interior and exterior damage, and if found, report it immediately to the carrier. Also check that all accessory items are accounted for and are damage free. Turn the blower wheel by hand to verify free rotation and check the damper (if supplied) for free operation.

WARNING!!

Installation of this ventilator should only be performed by a qualified professional who has read and understands these instructions and is familiar with proper safety precautions. Improper installation poses serious risk of injury due to electric shock, contact with rotating equipment, and other potential hazards. Read this manual thoroughly before installing or servicing this equipment. **ALWAYS** disconnect power prior to working on fan.

Save these instructions. This document is the property of the owner of this equipment and is required for future maintenance. Leave this document with the owner when installation or service is complete.

TABLE OF CONTENTS

WARRANTY.....	4
INSTALLATION.....	5
Mechanical.....	5
Site Preparation	5
Roof Mounting.....	5
Wall Mounting	6
Curb and Ductwork	6
Up-Blast Roof Mount Installation	7
Up-Blast Roof Mount Utility Installation	7
Up-Blast Wall Mount Installation	8
Up-Blast Through Wall Mount Installation	8
Down-Blast Installation.....	9
Up-Blast Utility Set Hinging Instructions.....	9
Typical Hinge Kit – Centrifugal Upblast.....	10
Typical Grease Box Installation	10
Up-Blast Utility Set Rain Cap Option.....	11
Up-Blast Utility Set Extension Option.....	11
Electrical	11
Copper Wire Ampacity	12
PSC (Permanent Split Capacitor) Motor Speed Control	13
ECM (Electronically Controlled Motor) Speed Control	13
Motorized Damper.....	13
Fan to Building Wiring Connection.....	14
OPERATION	15
Start Up.....	15
Special Tools Required	15
Start Up Procedure	15
Pulley Setscrew Torque.....	15
Pulley Alignment	16
Proper Belt Tension	16
Pulley Combination Chart.....	17
Troubleshooting	18
Troubleshooting Chart.....	18
MAINTENANCE	19
General Maintenance	19
Bearing Grease Charge.....	19
Bearing Grease Type	19
2 weeks after startup	20
Every 3 months	20
Yearly.....	20
Start-Up and Maintenance Documentation	21
Job Information	21
Fan Unit Information.....	21
Maintenance Record	21
Factory Service Department.....	22

WARRANTY

This equipment is warranted to be free from defects in materials and workmanship, under normal use and service, for a period of 12 months from date of shipment. This warranty shall not apply if:

1. The equipment is not installed by a qualified installer per the MANUFACTURER'S installation instructions shipped with the product,
2. The equipment is not installed in accordance with federal, state and local codes and regulations,
3. The equipment is misused or neglected,
4. The equipment is not operated within its published capacity,
5. The invoice is not paid within the terms of the sales agreement.

The MANUFACTURER shall not be liable for incidental and consequential losses and damages potentially attributable to malfunctioning equipment. Should any part of the equipment prove to be defective in material or workmanship within the 12-month warranty period, upon examination by the MANUFACTURER, such part will be repaired or replaced by MANUFACTURER at no charge. The BUYER shall pay all labor costs incurred in connection with such repair or replacement. Equipment shall not be returned without MANUFACTURER'S prior authorization and all returned equipment shall be shipped by the BUYER, freight prepaid to a destination determined by the MANUFACTURER.

INSTALLATION

It is imperative that this unit is installed and operated with the designed airflow and electrical supply in accordance with this manual. If there are any questions about any items, please call the service department at **1-866-784-6900** for warranty and technical support issues.

Mechanical

WARNING: DO NOT RAISE VENTILATOR BY THE HOOD, BLOWER OR MOTOR SHAFT, OR BEARINGS – USE LIFTING LUGS PROVIDED OR A SLING

Site Preparation

1. Provide clearance around installation site to safely rig and lift equipment into its final position. Supports must adequately support equipment. Refer to manufacturer's estimated weights.
2. Consider general service and installation space when locating unit.
3. Locate unit close to the space it will serve to reduce long, twisted duct runs.
4. The fan discharge must be located at least 10 feet away from any supply intakes. The fan discharge shall be located in accordance with the applicable building code provisions.

Roof Mounting

1. Ventilators are designed for installation atop a prefabricated or factory built roof curb. Follow manufacturer's instructions for proper curb installation.
2. If a backdraft damper is required, it should be secured within the curb using sheet metal screws, to the bottom of a damper box or damper support flanges located below the roof deck.
CAUTION: NFPA-96 RECOMMENDS THAT DAMPERS SHOULD NOT BE INSTALLED WHEN EXHAUSTER IS USED FOR REMOVAL OF SMOKE AND GREASE LADEN VAPORS FROM COMMERCIAL KITCHEN EQUIPMENT. CONSULT STATE AND LOCAL CODES FOR DETAILED REQUIREMENTS.
3. If an up-blast fan is used for kitchen hood exhaust, ensure discharge is at least 40 inches above the roof surface in accordance with NFPA96.
4. On an up-blast fan, normally the power cord is brought through the conduit tube located on the top skirt on the outside of the unit.
5. Secure ventilator curb through vertical portion of the ventilator base assembly flange using a minimum of eight (8) lug screws, anchor bolts, or other suitable fasteners (not furnished).
6. Before connecting fan motor to power source verify power line wiring is de-energized.
7. Connect power supply wiring to the motor as indicated on the motor nameplate or terminal box cover. Make certain that the power source is compatible with the requirements of your equipment.
8. Before powering up fan check ventilator wheel for free rotation.
9. Check all fasteners for tightness.
10. Re-install motor dome.
11. A drain pipe is provided for single-point drainage of water and residue on up-blast fans. The drain pipe should be positioned towards the roof slope. Some means for collection of this residue must be provided, either a container directly under the trough or use of an adapter and pipe to carry the residue to a remote collection point. An optional down spout and grease collection box is available as an accessory item for up-blast fans.

Wall Mounting

1. The same instructions, warnings and notes found under Roof Mounting section will apply. Refer to steps 2 and 3, and steps 5 through 8.
2. **Masonry Wall:** Around the wall opening install an angle iron frame at least 2" x 2" x 1/4". Frame should be approximately 1/2" smaller than the inside base dimension of the ventilator. Secure the lead cinch type anchors with non-ferrous bolts (3 per side). The ventilator should be mounted to the mounting angle with self-taping sheet metal screws (3 per side).
3. **Wood Siding:** Around the wall opening install a wooden frame 2" high x 2" wide. Frame should be approximately 1/2" smaller than the inside base dimension of the ventilator. Secure with counter-sunk expansion type lag bolts (3 per side). The ventilator should then be mounted to the mounting frame with the square head wood screws (3 per side) 3/8" minimum.
4. Steel wall mount brackets are also available as a factory option for the fan.
5. The mounting flange connections should be coated with a suitable caulking compound or an approved waterproof mastic sealer.
6. Wall mount application is not recommended from fans with wheels 30" or larger.

IMPORTANT: OSHA REGULATIONS REQUIRE THE VENTILATOR TO BE MOUNTED AT LEAST EIGHT (8) FEET ABOVE GROUND OR FLOOR LEVEL.

Curb and Ductwork

This fan was specified for a specific CFM and static pressure. The ductwork attached to this unit will significantly affect the airflow performance. Flexible ductwork and square elbows should not be used. Also, transitions and turns in ductwork near the fan inlet will cause system effect and will drastically increase the static pressure and reduce airflow. **Follow SMACNA guides and recommendations for the remaining duct run.** Fans designed for rooftop installation should be installed on a prefabricated or factory built roof curb. Follow curb manufacturer's instructions for proper curb installation. Curbs should be connected to structural roof members with at least four (3) lug screws, anchor bolts, or other suitable fasteners (not furnished) per curb flange. Curb flanges should be caulked to roof.

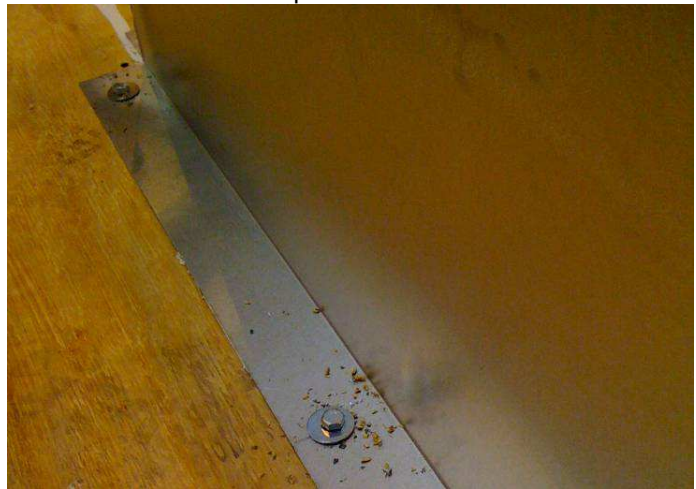

The fan should be installed on a curb and/or rail elevated not less than 14" above any surface. Be sure duct connection and fan outlet are properly aligned and sealed. Secure fan to curb through vertical portion of the ventilator base assembly flange using a minimum of eight (8) lug screws, anchor bolts, or other suitable fasteners (not furnished). Shims may be required depending upon curb installation and roofing material. Check all fasteners for tightness. The diagrams below show different mechanical installation configurations.

Up-Blast Roof Mount Installation

FEATURES:

- ROOF MOUNTED FANS
- RESTAURANT MODEL
- UL762
- AMCA SOUND AND AIR CERTIFIED
- WIRING FROM MOTOR TO DISCONNECT SWITCH
- WEATHERPROOF DISCONNECT
- HIGH HEAT OPERATION 300°F (149°C)
- GREASE CLASSIFICATION TESTING

NORMAL TEMPERATURE TEST
EXHAUST FAN MUST OPERATE CONTINUOUSLY WHILE EXHAUSTING AIR AT 300°F (149°C) UNTIL ALL FAN PARTS HAVE REACHED THERMAL EQUILIBRIUM, AND WITHOUT ANY DETERIORATING EFFECTS TO THE FAN WHICH WOULD CAUSE UNSAFE OPERATION.

ABNORMAL FLARE-UP TEST
EXHAUST FAN MUST OPERATE CONTINUOUSLY WHILE EXHAUSTING BURNING GREASE VAPORS AT 600°F (316°C) FOR A PERIOD OF 15 MINUTES WITHOUT THE FAN BECOMING DAMAGED TO ANY EXTENT THAT COULD CAUSE AN UNSAFE CONDITION.

OPTIONS:

- GREASE BOX
- HINGED FAN
- PITCHED CURB
- INSULATED CURB

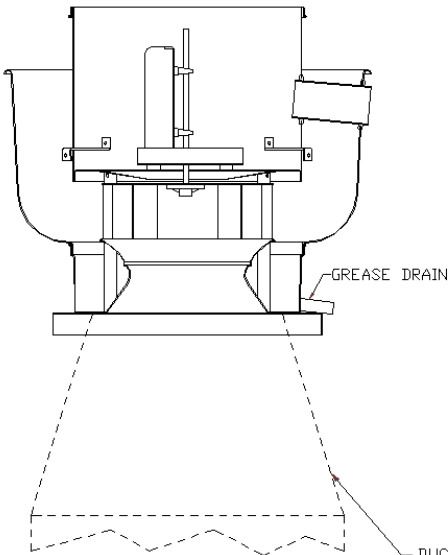

DUCTWORK BETWEEN EXHAUST RISER ON HOOD AND FAN (BY OTHERS)

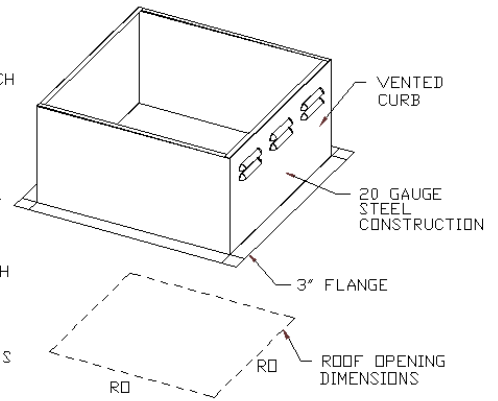

PITCHED CURBS ARE AVAILABLE FOR PITCHED ROOFS.

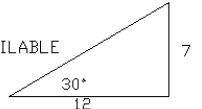

SPECIFY PITCH:
EXAMPLE: 7/12 PITCH = 30° SLOPE

Up-Blast Roof Mount Utility Installation

FEATURES:

- ROOF MOUNTED FANS
- RESTAURANT MODEL
- UL762
- HIGH HEAT OPERATION DIRECT DRIVE 300°F (149°C)
- HIGH HEAT OPERATION BELT DRIVE 500°F (260°C)
- HEAT SLINGER
- GREASE CLASSIFICATION TESTING
- TILT OUT WHEEL
- LOCKING PIN FOR POWER PACK
- MOTOR WEATHER COVER

NORMAL TEMPERATURE TEST BELT DRIVE
EXHAUST FAN MUST OPERATE CONTINUOUSLY WHILE EXHAUSTING AIR AT 500°F (260°C) UNTIL ALL FAN PARTS HAVE REACHED THERMAL EQUILIBRIUM, AND WITHOUT ANY DETERIORATING EFFECTS TO THE FAN WHICH WOULD CAUSE UNSAFE OPERATION.

NORMAL TEMPERATURE TEST DIRECT DRIVE
EXHAUST FAN MUST OPERATE CONTINUOUSLY WHILE EXHAUSTING AIR AT 300°F (149°C) UNTIL ALL FAN PARTS HAVE REACHED THERMAL EQUILIBRIUM, AND WITHOUT ANY DETERIORATING EFFECTS TO THE FAN WHICH WOULD CAUSE UNSAFE OPERATION.

ABNORMAL FLARE-UP TEST BELT & DIRECT DRIVE
EXHAUST FAN MUST OPERATE CONTINUOUSLY WHILE EXHAUSTING BURNING GREASE VAPORS AT 600°F (316°C) FOR A PERIOD OF 15 MINUTES WITHOUT THE FAN BECOMING DAMAGED TO ANY EXTENT THAT COULD CAUSE AN UNSAFE CONDITION.

OPTIONS:

- GREASE BOX
- PITCHED CURB
- INSULATED CURB
- RAIN CAP

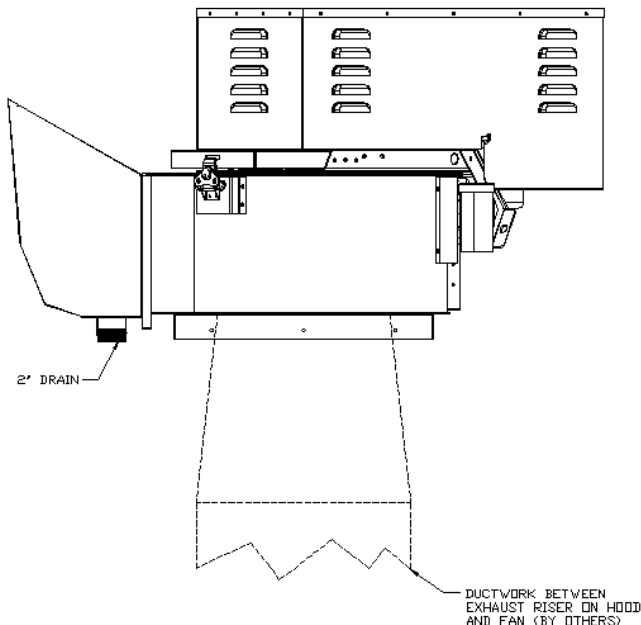

DUCTWORK BETWEEN EXHAUST RISER ON HOOD AND FAN (BY OTHERS)

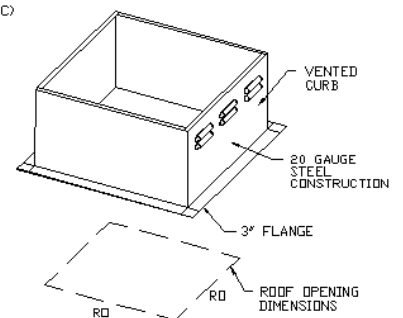

PITCHED CURBS ARE AVAILABLE FOR PITCHED ROOFS.

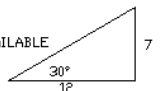

SPECIFY PITCH:
EXAMPLE: 7/12 PITCH = 30° SLOPE

Up-Blast Wall Mount Installation

WALL MOUNT BRACKET
REV#E 03/02/03

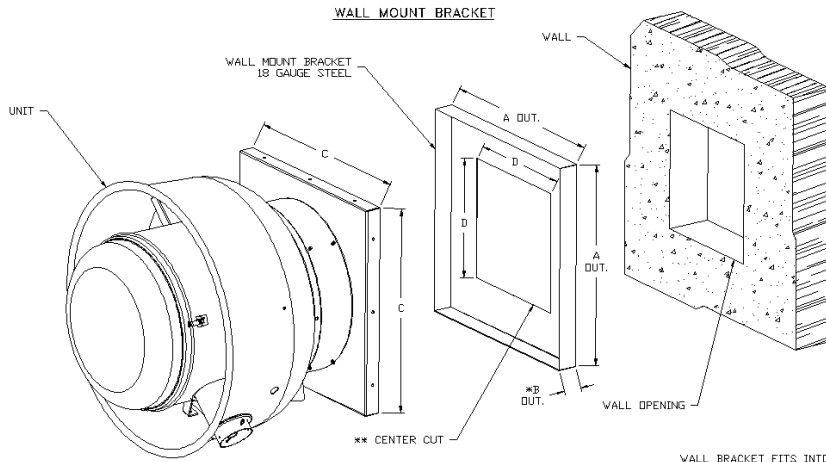

A OUT.	B OUT.	C	D
18 1/2	2	19	13
20 1/2	2	21	16
21 1/2	2	22	16
24 1/4	2	24 3/4	20
25 1/2	2	26	20
27 1/2	2	28	24
32 1/2	2	33	28

WALL BRACKET FITS INTO BASE OF FAN
SELF DRILLING SCREWS SHOULD BE USED
FOR UNIT ATTACHMENT TO WALL MOUNT BRACKET
* "B" DIMENSION = 5" WHEN USED WITH DAMPER
** CENTERED IN WALL MOUNT

Up-Blast Through Wall Mount Installation

THROUGH WALL CURB INSTALLATION
REV#A 03/02/07

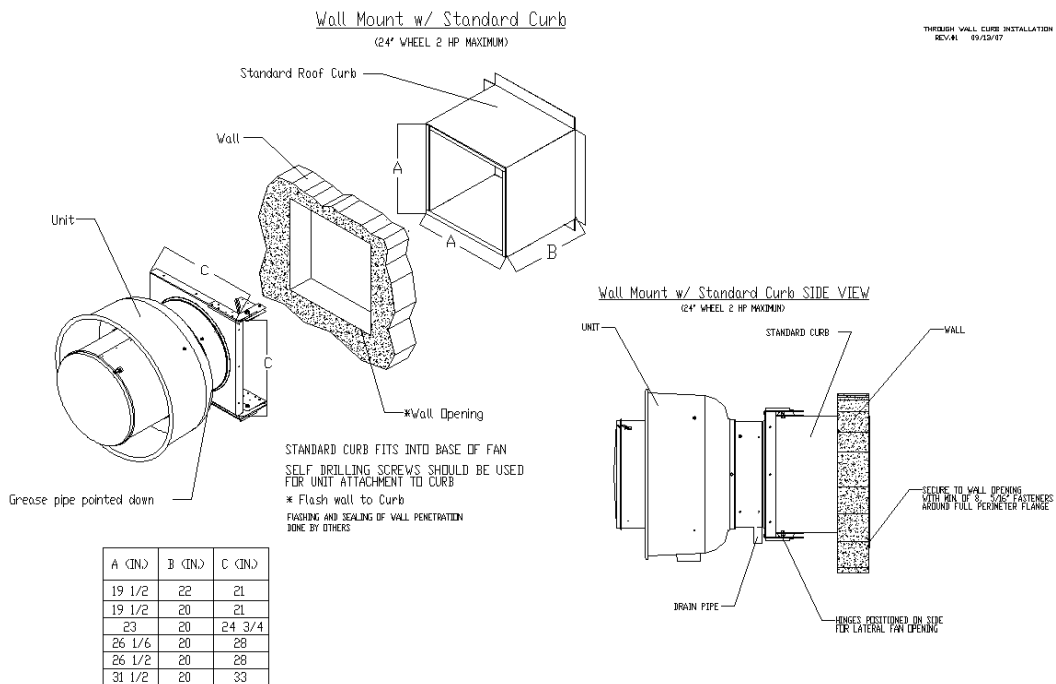

A (IN)	B (IN)	C (IN)
19 1/2	22	21
19 1/2	20	21
23	20	24 3/4
26 1/6	20	28
26 1/2	20	28
31 1/2	20	33

Down-Blast Installation

FEATURES:

- ROOF MOUNTED FANS
- UL705
- AMCA SOUND AND AIR CERTIFIED
- WIRING FROM MOTOR TO DISCONNECT SWITCH
- DISCONNECT SWITCH
- STANDARD BIRD SCREEN

OPTIONS:

- HINGED FAN
- PITCHED CURB
- INSULATED CURB
- BACKDRAFT DAMPER

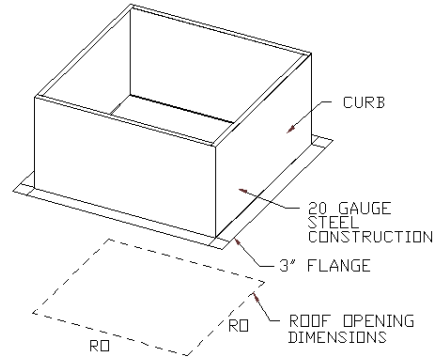
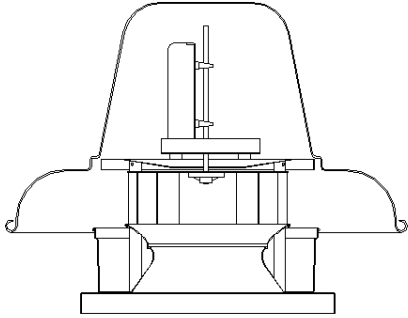

BACKDRAFT DAMPER INSTALLATION

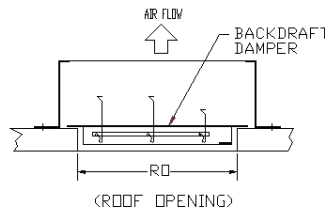

PITCHED CURBS ARE AVAILABLE FOR PITCHED ROOFS.
SPECIFY PITCH:
EXAMPLE: 7/12 PITCH = 30° SLOPE

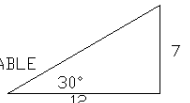

Up-Blast Utility Set Hinging Instructions

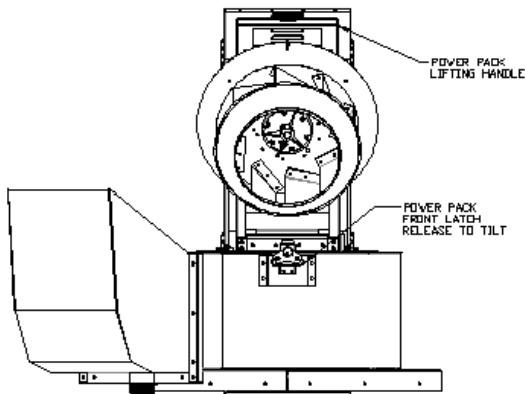

UTILITY SETS MAY NOT BE WALL MOUNTED

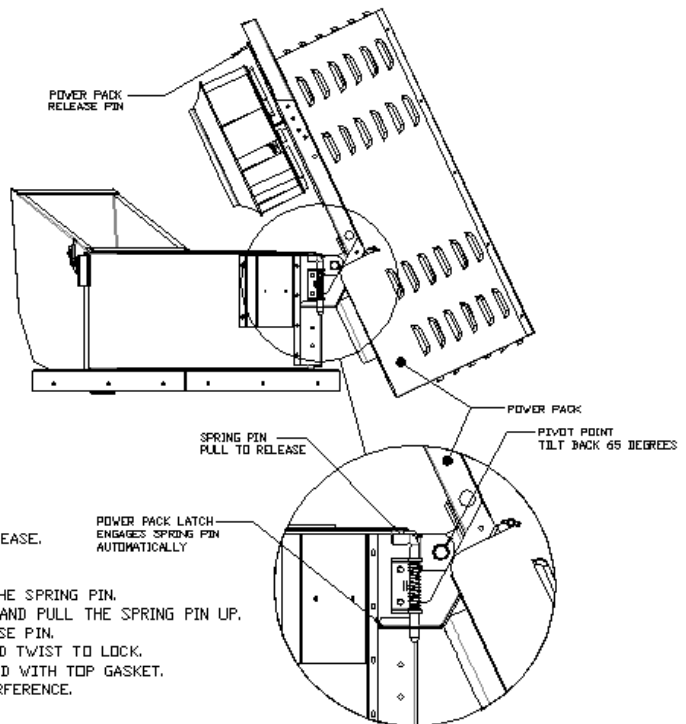

HINGING INSTRUCTIONS:

- 1 - REMOVE THE POWER PACK RELEASE PIN.
- 2 - TWIST AND TURN THE POWER PACK FRONT LATCH TO RELEASE.
- 3 - LIFT THE POWER PACK USING THE FRONT HANDLE.
- 4 - THE POWER PACK WILL TILT BACK 65 DEGREES.
- 5 - THE POWER PACK LATCH WILL AUTOMATICALLY ENGAGE THE SPRING PIN.
- 6 - TO CLOSE THE POWER PACK, HOLD THE LIFTING HANDLE AND PULL THE SPRING PIN UP.
- 7 - LOWER THE POWER PACK DOWN AND REPLACE THE RELEASE PIN.
- 8 - ENGAGE THE FRONT LATCH INTO THE LIFTING HANDLE AND TWIST TO LOCK.
- 9 - INSPECT THE POWER PACK. TOP PLATE SHOULD BE SEALED WITH TOP GASKET.
- 10 - TURN THE WHEEL TO MAKE SURE THERE ISN'T ANY INTERFERENCE.

Typical Hinge Kit – Centrifugal Upblast

HINGE KIT INSTALLATION

CLOSED POSITION

OPEN POSITION

ATTENTION!
INSTALLER MUST READ LABEL NEAR DISCONNECT SWITCH MESSAGE ON LABEL *INSTALLER SHOULD SUPPLY ENOUGH ELECTRICAL CORD TO LET FAN MAKE COMPLETE SWING*

DETAIL "A"

7 1/4 APPROX. 2 APPROX.

PARTS INCLUDED

2 - FAN PLATES (LEFT & RIGHT)
2 - CURB PLATES (LEFT & RIGHT)
2 - WHIZ BOLTS
6 - WHIZ NUTS
SHEET METAL SCREWS
12 - SHORT (3/2" LG.)
12 - LONG (3/4" LG.)

HINGE KIT FIELD INSTALLATION

STEP 1)
ASSEMBLE FAN PLATE WITH CURB PLATE AS SHOWN ON PIC. 1 AND PIC. 2 (IF PARTS ARE NOT ASSEMBLED).

STEP 2)
SEE DETAIL "A" FOR POSITIONING FAN PLATE ON FAN BASE. LINE UP FAN BASE EDGE TO INSIDE EDGE OF FAN PLATE AS SHOWN ON PIC. 3.

STEP 3)
SCREW THE FAN PLATE TO THE FAN BASE USING THE (12) SHORT 1/2" LG. SHEET METAL SCREWS. NOTE: IF THE SCREWS HIT THE CURB, THEN RUN THE SCREWS FROM INSIDE THE FAN BASE. ALWAYS BE SURE THAT SCREWS DO NOT INTERFERE WITH CURB WHEN FAN SWINGS SEE PIC. 4.

STEP 4)
SCREW THE CURB PLATE TO THE CURB USING THE (12) LONG 3/4" LG. SHEET METAL SCREWS. TIGHTEN NUT AND BOLT ASSEMBLY, ENSURE FAN SWINGS PROPERLY.

Typical Grease Box Installation

GREASE BOX INSTALLATION

CLOSED POSITION

OPEN POSITION

5 1/16
17 1/8
3 3/4

3 APPROX.

PARTS INCLUDED

GREASE BOX
GREASE BOX COVER
GREASE PIPE
SHEET METAL SCREWS
3 - LONG (3/4" LG.)

GREASE BOX FIELD INSTALLATION

STEP 1)
ATTACH GREASE BOX COVER TO THE CURB. HOLD 3" DIMENSION AS SHOWN ON PIC. 1. SCREW GREASE BOX COVER TO CURB USING (3) LONG (3/4" LG.) SCREWS AS SHOWN ON PIC. 2.

STEP 2)
ATTACH GREASE BOX TO GREASE BOX COVER, SLIDE AND DROP AS SHOWN ON PIC. 3.

STEP 3)
INSTALL GREASE PIPE AS SHOWN ON PIC. 4.

Up-Blast Utility Set Rain Cap Option

Rain Cap Option - Up Blast Utility Set

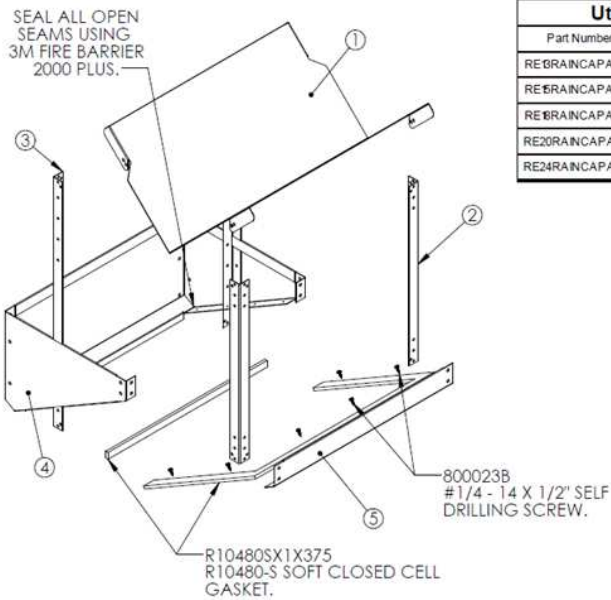

Utility Set Option - Rain Cap - Assembly	
Part Number	Description
RE6RAINCAPASSY	RE 6 - RAIN CAP ASSEMBLY OPTION
RE5RAINCAPASSY	RE 5 - RAIN CAP ASSEMBLY OPTION
RE8RAINCAPASSY	RE 8 - RAIN CAP ASSEMBLY OPTION
RE20RAINCAPASSY	RE 20 - RAIN CAP ASSEMBLY OPTION
RE24RAINCAPASSY	RE 24 - RAIN CAP ASSEMBLY OPTION

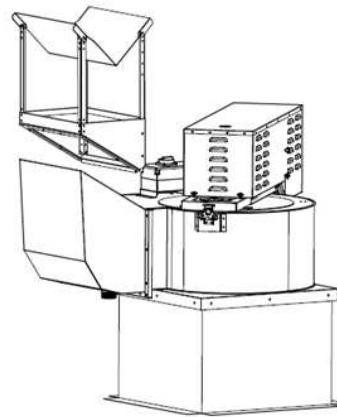

Up-Blast Utility Set Extension Option

Extension Option - Up Blast Utility Set

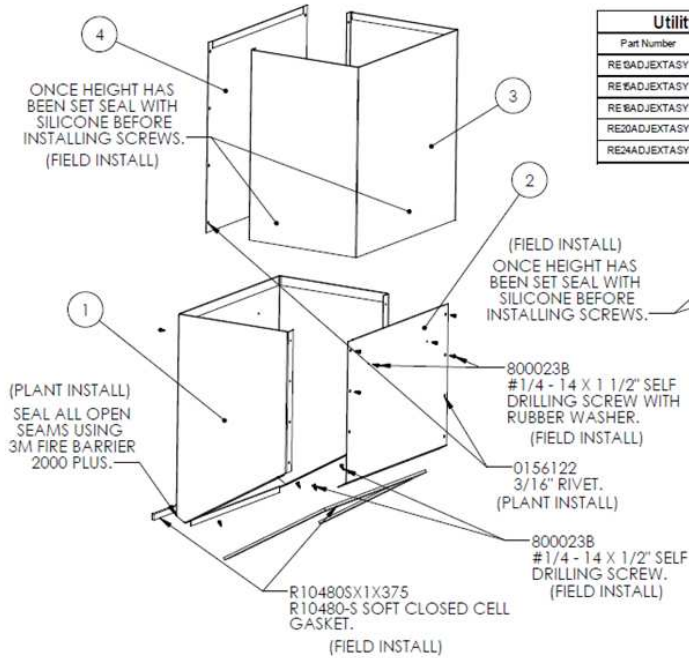

Utility Set Option - Extension - Assembly	
Part Number	Description
RE6ADJEXTASY	RE 6 - EXTENSION ASSEMBLY OPTION
RE5ADJEXTASY	RE 5 - EXTENSION ASSEMBLY OPTION
RE8ADJEXTASY	RE 6 - EXTENSION ASSEMBLY OPTION
RE20ADJEXTASY	RE 20 - EXTENSION ASSEMBLY OPTION
RE24ADJEXTASY	RE 24 - EXTENSION ASSEMBLY OPTION

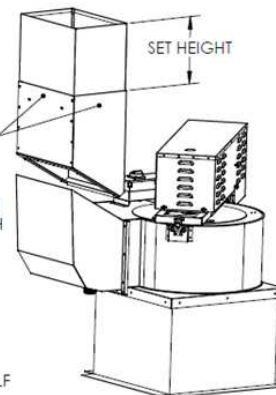

Electrical

Before connecting power to the fan, read and understand this entire section of this document. As-built wiring diagrams are available with each fan by the factory.

Electrical wiring and connections should be done in accordance with local ordinances and the National Electric Code, ANSI/NFPA70. Be sure the voltage and phase of the power supply and the wire ampere capacity is in accordance with the motor nameplate. For additional safety information refer to AMCA publication 410-96, *Recommended Safety Practices for Users and Installers of Industrial and Commercial Fans*.

1. Always **disconnect power** before working on or near a fan. Lock and tag the disconnect switch or breaker to prevent accidental power up.
2. A disconnect switch is shipped with every fan. The switch is located on the exterior of up-blast fans and in the interior of down-blast fans. On down-blast direct drive fans, the disconnect function is built into the speed controller.
3. A dedicated branch circuit should supply the motor circuit with short circuit protection according to the National Electric Code. This dedicated branch should be run to the junction box mentioned above and connected as shown in a following illustration labeled "Fan to Building Wiring Connection".
4. Make certain that the power source is compatible with the requirements of your equipment. The fan nameplate identifies the **proper phase and voltage** of the motor.
5. Before connecting fan to building power source, verify power line wiring is de-energized.
6. Secure the power cable to prevent contact with sharp objects.
7. Do not kink power cable and never allow the cable to come in contact with oil, grease, hot surfaces or chemicals.
8. Before powering up fan check fan wheel for free rotation and make sure that the interior of the fan is free of loose debris or shipping materials.
9. If any of the original wire supplied with the fan must be replaced, it must be replaced with type TW wire or equivalent.

WARNING!!
Disconnect power before installing or servicing fan. High voltage electrical input is needed for this equipment. This work should be performed by a qualified electrician.

Copper Wire Ampacity

Wire Size AWG	Maximum Amps
14	20
12	25
10	30
8	40
6	55
4	70

IMPORTANT: FANS WITH HINGE KITS REQUIRE ENOUGH SLACK IN THE WIRING TO THE FAN TO ALLOW FAN TO TILT BACK TO THE OPEN POSITION. ELECTRICIAN MUST CHECK THIS AND ACCOUNT FOR THE RANGE OF MOTION OF THE FAN.

PSC (Permanent Split Capacitor) Motor Speed Control

Some single phase direct drive fans contain speed controls that regulate the amount of voltage going to the motor. Specific PSC motors must be used in conjunction with speed controls. The speed control has a knob with an off position, and high to low range. At high speed, the speed control allows all of the line voltage to pass right to the motor.



A minimum speed adjustment is provided to allow independent control of the minimum speed setting. Minimum speed adjustment ensures motor runs with sufficient torque to prevent stalling. To adjust this:

- 1) Motor must be in actual operating conditions to achieve proper speed adjustment. Motor will not slow down unless proper load is applied.
- 2) Turn main control knob to lowest speed position.
- 3) Locate and adjust minimum speed setting and adjust with small screw driver. This can be found under the speed control faceplate. (rotate clockwise to decrease minimum speed; counter-clockwise to increase minimum speed).
- 4) Motor will now operate from this preset minimum speed to full speed.

The lowest minimum voltage that may be applied to these motors is 65VAC. Running lower voltages to the motor can cause premature failure and overheating problems.

ECM (Electronically Controlled Motor) Speed Control

ECM motors and control allows accurate manual adjustment of fan speed. The benefit of ECM motors is exceptional efficiency, performance, and motor life.

The control used with ECM motors features a 4 digit LED numerical display. The blue knob on the control allows the user to set the flow index with a screwdriver. Twenty seconds later, the display shows the motor RPM. Then, the display periodically alternates between the flow index and motor RPM. The flow index has a range of 0 to 100% and is typically linear with motor RPM.



The ECM control requires a 24 VAC input and can locally turn the motor on and off. The motor can be adjusted between 300 RPM and maximum speed with this control.

NOTE: To adjust the speed of 3 phase direct drive motors, a variable frequency drive is required.

Motorized Damper

On units shipped with the optional motorized damper, power must be supplied to the damper according to the damper nameplate. The damper motor is controlled external to the fan. **External wiring to the damper motor is required.**

Fan to Building Wiring Connection

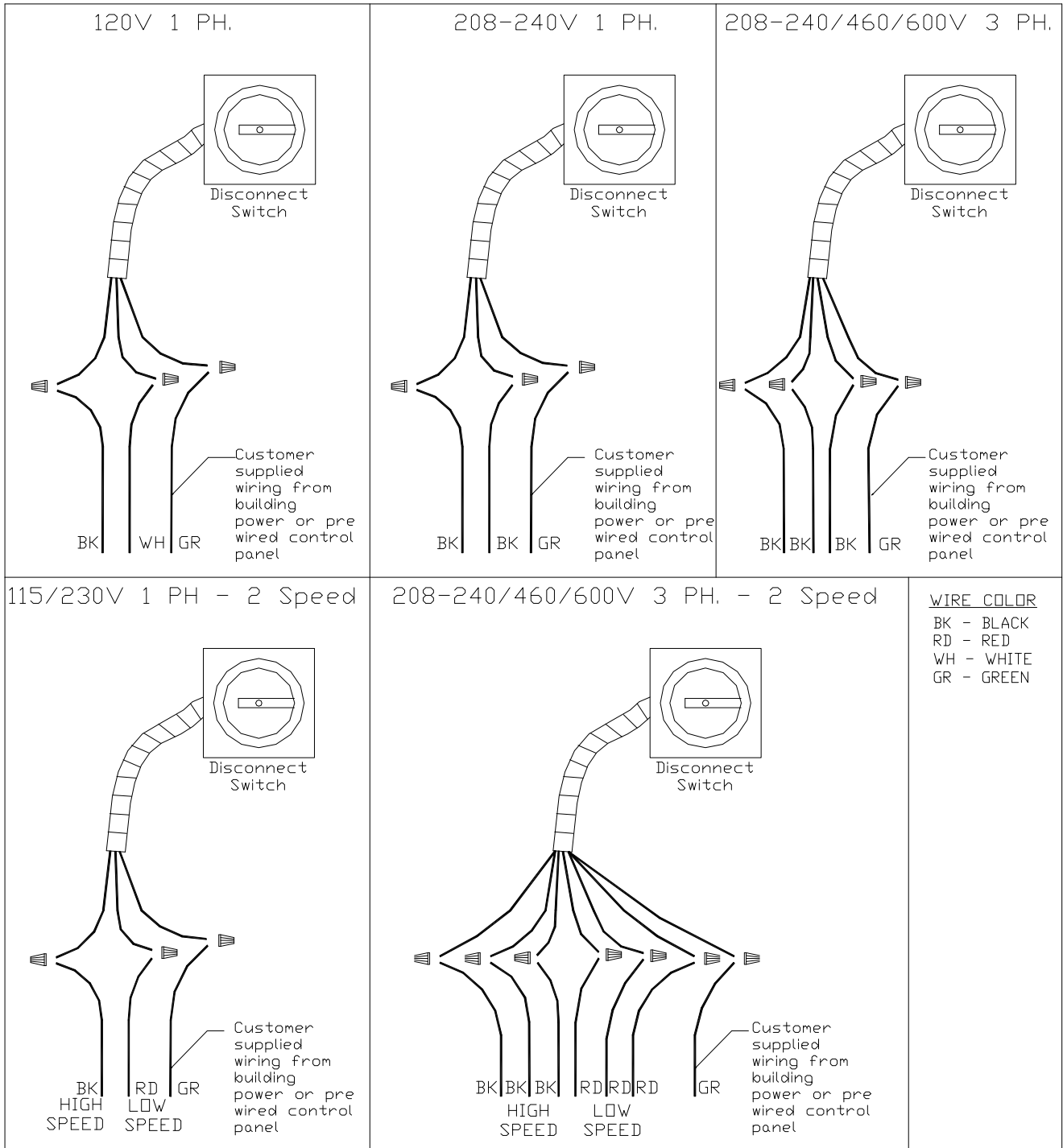

OPERATION

Prior to starting up or operating the ventilator, check all fasteners for tightness. In particular, check the set screw in the wheel hub, bearings and the fan sheaves (pulleys). With power to the fan **OFF** or prior to connecting ventilator to power, turn the fan wheel by hand to be sure it is not striking the inlet or any obstacles. Re-center if necessary.

Start Up

Special Tools Required

- AC Voltage Meter
- Tachometer
- Amperage Meter
- Standard Hand Tools

Start Up Procedure

1. Check all electrical connections for tightness and continuity.
2. Check pulley alignment and belt tension as described below for belt drive fans.
3. Inspect the condition of the damper and damper linkage, if provided.
4. Inspect the air-stream for obstructions or debris in wheel.
5. Compare the supplied **voltage** with the fan's nameplate voltage. If this does not match, correct the problem.
6. Start the fan up, by turning the external disconnect to the **ON** position, and shut it **OFF** immediately to **check rotation of the wheel** with the directional arrow on the blower scroll. Reversed rotation will result in poor air performance, motor overloading and possible burnout. For units equipped with a single-phase motor check the motor wiring diagram to change rotation. For 3-phase motors, any two power leads can be interchanged to reverse motor direction.
7. When the fan is started up, observe the operation and check for any unusual noises.
8. Switch the external disconnect back to the **ON** position and with the air system in full operation and all ducts attached, measure the system airflow. Motor sheave (pulley) is variable pitch, and allows for an increase or decrease of the fan RPM to adjust the airflow, as shown in the illustration below. For your convenience, a RPM chart is included in the following pages. If the fan is a direct drive version, it may have a speed control to adjust speed.
9. Once the proper airflow is achieved, measure and record the fan speed with a reliable tachometer. **Caution - Excessive speed will result in motor overloading or bearing failure. Do not set fan RPMs higher than specified in the maximum RPM chart.** See the troubleshooting guide for more information.
10. Measure and record the **voltage** and **amperage** to the motor and compare with the motor nameplate to determine if the motor is operating under safe load condition.
11. Once the rpm of the ventilator has been properly set, disconnect power and recheck belt tension and pulley alignment as described below.

Pulley Setscrew Torque

Thread Size	Torque (IN/Lb)
No. 10 (bushing)	32
1/4" (bushing)	72
5/16"	130

Pulley Adjustment Illustration

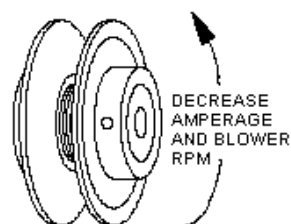

Pulley Adjustment (Belt Drive Fans)

The adjustable motor pulley is factory set for the RPM specified. Speed can be increased by closing or decreased by opening the adjustable motor sheave. Two groove variable pitch pulleys must be adjusted an equal number of turns open or closed. Any increase in speed represents a substantial increase in horsepower required by the unit. Motor amperage should always be checked to avoid serious damage to the motor when the speed is varied. Always torque setscrews according to the setscrew torque chart.

Pulley Alignment

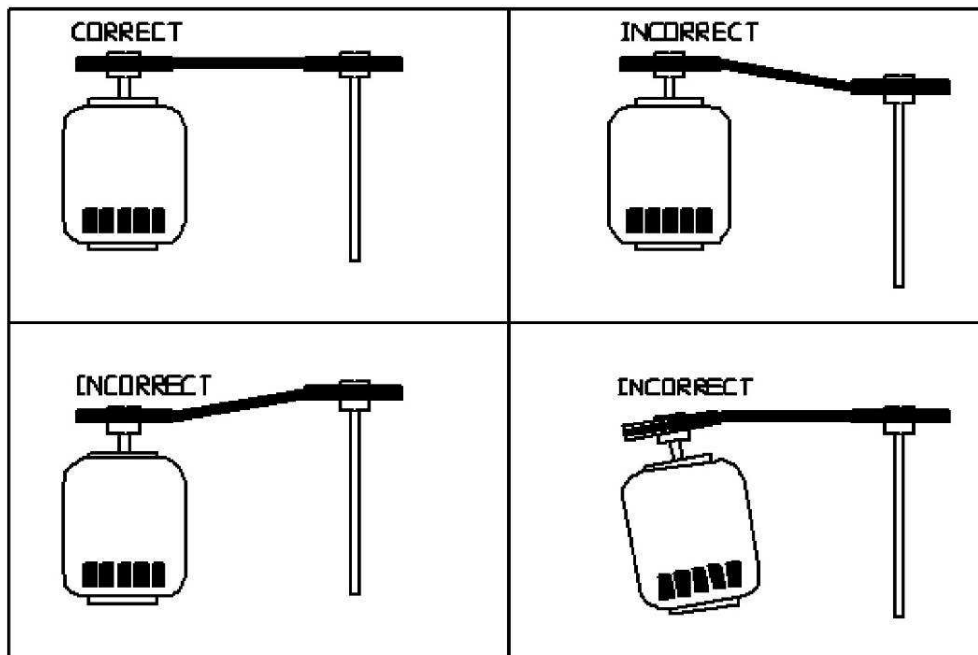

Proper Belt Tension

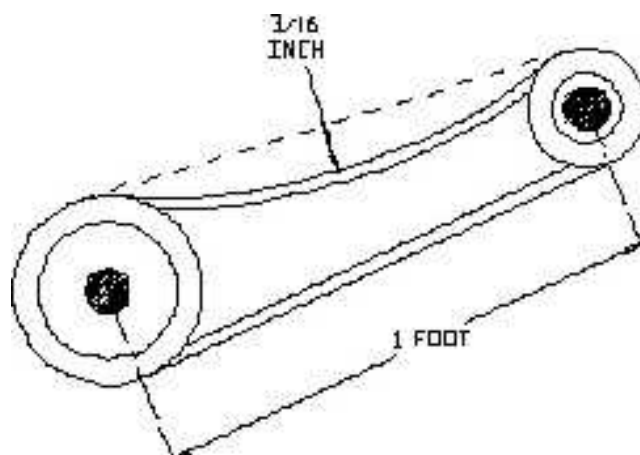

Pulley Combination Chart

Motor RPM			1725												
1/3 to 1-1/2 HP AX BELTS			MOTOR PULLEY 1V134	Dd1 1.9	Dd2 2.9	Pd1 2	Pd2 3	TURNS ON MOTOR PULLEY							
BLOWER PULLEY	DATUM DIAMETER	PITCH DIAMETER	Open										Closed		
AK114	11	11.2	5	4 1/2	4	3 1/2	3	2 1/2	2	1 1/2	1	1/2	0		
			308	323	339	354	370	385	400	416	431	447	462		
1/3 to 1-1/2 HP AX BELTS			MOTOR PULLEY 1V140	Dd1 2.4	Dd2 3.4	Pd1 2.6	Pd2 3.6	TURNS ON MOTOR PULLEY							
BLOWER PULLEY	DATUM DIAMETER	PITCH DIAMETER	Open										Closed		
AK114	11	11.2	5	4 1/2	4	3 1/2	3	2 1/2	2	1 1/2	1	1/2	0		
AK94	9	9.2	488	506	525	544	563	581	600	619	638	656	675		
AK79	7.5	7.7	582	605	627	650	672	694	717	739	762	784	806		
AK66	6.2	6.4	701	728	755	782	809	836	863	889	916	943	970		
AK54	5	5.2	863	896	929	962	995	1028	1062	1095	1128	1161	1194		
AK46	4.2	4.4	1019	1059	1098	1137	1176	1215	1255	1294	1333	1372	1411		
AK39	3.5	3.7	1212	1259	1305	1352	1399	1445	1492	1539	1585	1632	1678		
AK32	3	3.2	1402	1455	1509	1563	1617	1671	1725	1779	1833	1887	1941		
2 to 5 HP BX BELTS			MOTOR PULLEY 2VP42	Dd1 2.9	Dd2 3.9	Pd1 3	Pd2 4	TURNS ON MOTOR PULLEY							
BLOWER PULLEY	DATUM DIAMETER	PITCH DIAMETER	Open										Closed		
2BK160H	15.4	15.7	6	5 1/2	5	4 1/2	4	3 1/2	3	2 1/2	2	1 1/2	1	1/2	0
2BK140H	13.4	13.7	378	388	399	409	420	430	441	451	462	472	483	493	504
2BK120H	11.4	11.7	442	455	467	479	491	504	516	528	541	553	565	577	590
2BK110H	10.4	10.7	484	497	511	524	537	551	564	578	591	605	618	631	645
2BK100H	9.4	9.7	534	548	563	578	593	608	622	637	652	667	682	697	711
2BK90H	8.4	8.7	595	611	628	644	661	677	694	710	727	744	760	777	793
2BK80H	7.4	7.7	672	691	709	728	747	765	784	803	821	840	859	877	896
2BK70H	6.4	6.7	772	794	815	837	858	880	901	923	944	965	987	1008	1030
2BK60H	5.4	5.7	908	933	958	984	1009	1034	1059	1084	1110	1135	1160	1185	1211
2BK55H	4.9	5.2	995	1023	1050	1078	1106	1133	1161	1189	1216	1244	1272	1299	1327
2BK50H	4.4	4.7	1101	1132	1162	1193	1223	1254	1285	1315	1346	1376	1407	1438	1468
7-1/2 to 10 HP BX BELTS			MOTOR PULLEY 2VP60	Dd1 4.3	Dd2 5.5	Pd1 4.7	Pd2 5.9	TURNS ON MOTOR PULLEY							
BLOWER PULLEY	DATUM DIAMETER	PITCH DIAMETER	Open										Closed		
2BK160H	15.4	15.7	6	5 1/2	5	4 1/2	4	3 1/2	3	2 1/2	2	1 1/2	1	1/2	0
2BK140H	13.4	13.7	516	527	538	549	560	571	582	593	604	615	626	637	648
2BK120H	11.4	11.7	592	604	617	630	642	655	667	680	693	705	718	730	743
2BK110H	10.4	10.7	683	708	722	737	752	767	781	796	811	826	840	855	870
2BK100H	9.4	9.7	758	774	790	806	822	838	854	871	887	903	919	935	951
2BK90H	8.4	8.7	836	854	871	889	907	925	943	960	978	996	1014	1031	1049
2BK80H	7.4	7.7	932	952	972	991	1011	1031	1051	1071	1091	1110	1130	1150	1170
			1053	1075	1098	1120	1143	1165	1187	1210	1232	1255	1277	1299	1322
3 to 5 HP BX BELTS			MOTOR PULLEY 2VP42	Dd1 2.9	Dd2 3.9	Pd1 3	Pd2 4	TURNS ON MOTOR PULLEY							
BLOWER PULLEY	DATUM DIAMETER	PITCH DIAMETER	Open										Closed		
2B5V278	27.8	28.1	6	5 1/2	5	4 1/2	4	3 1/2	3	2 1/2	2	1 1/2	1	1/2	0
2B5V250	25	25.3	184	189	194	200	205	210	215	220	225	230	235	240	246
2B5V234	23.4	23.7	205	210	216	222	227	233	239	244	250	256	261	267	273
2B5V200	20	20.3	218	224	230	237	243	249	255	261	267	273	279	285	291
2B5V184	18.4	18.7	255	262	269	276	283	290	297	304	312	319	326	333	340
2B5V160	16	16.3	277	284	292	300	307	315	323	331	338	346	354	361	369
2B5V160	16	16.3	317	326	335	344	353	362	370	379	388	397	406	414	423
2B5V154	15.4	15.7	330	339	348	357	366	375	385	394	403	412	421	430	439
2B5V136	12.6	12.9	401	412	423	435	446	457	468	479	490	501	513	524	535
2B5V124	12.4	12.7	407	419	430	441	453	464	475	487	498	509	521	532	543
2B5V110	11	11.3	458	471	483	496	509	522	534	547	560	572	585	598	611
7-1/2 to 10 HP BX BELTS			MOTOR PULLEY 2VP60	Dd1 4.3	Dd2 5.5	Pd1 4.7	Pd2 5.9	TURNS ON MOTOR PULLEY							
BLOWER PULLEY	DATUM DIAMETER	PITCH DIAMETER	Open										Closed		
2B5V278	27.8	28.1	289	295	301	307	313	319	325	331	338	344	350	356	362
2B5V250	25	25.3	320	327	334	341	348	355	361	368	375	382	389	395	402
2B5V234	23.4	23.7	342	349	357	364	371	378	386	393	400	408	415	422	429
2B5V200	20	20.3	399	408	416	425	433	442	450	459	467	476	484	493	501
2B5V184	18.4	18.7	434	443	452	461	470	480	489	498	507	517	526	535	544
2B5V160	16	16.3	497	508	519	529	540	550	561	571	582	593	603	614	624
2B5V154	15.4	15.7	516	527	538	549	560	571	582	593	604	615	626	637	648
2B5V136	12.6	12.9	628	642	655	669	682	695	709	722	735	749	762	776	789
2B5V124	12.4	12.7	638	652	666	679	693	706	720	733	747	761	774	788	801
2B5V110	11	11.3	717	733	748	763	779	794	809	824	840	855	870	885	901
15 to 20 HP BX BELTS			MOTOR PULLEY 2VP75	Dd1 5.8	Dd2 7	Pd1 6.2	Pd2 7.4	TURNS ON MOTOR PULLEY							
BLOWER PULLEY	DATUM DIAMETER	PITCH DIAMETER	Open										Closed		
2B5V278	27.8	28.1	6	5 1/2	5	4 1/2	4	3 1/2	3	2 1/2	2	1 1/2	1	1/2	0
2B5V250	25	25.3	381	387	393	399	405	411	417	424	430	436	442	448	454
2B5V234	23.4	23.7	423	430	436	443	450	457	464	470	477	484	491	498	505
2B5V200	20	20.3	451	459	466	473	480	488	495	502	509	517	524	531	539
2B5V200	20	20.3	527	535	544	552	561	569	578	586	595	603	612	620	629
2B5V184	18.4	18.7	572	581	590	600	609	618	627	636	646	655	664	673	683
2B5V160	16	16.3	656	667	677	688	698	709	720	730	741	751	762	773	783
2B5V154	15.4	15.7	681	692	703	714	725	736	747	758	769	780	791	802	813
2B5V136	12.6	12.9	829	842	856	869	883	896	909	923	936	949	963	976	990

Troubleshooting

The following table lists causes and corrective actions for possible problems with the fan units. Review this list prior to consulting manufacturer.

Troubleshooting Chart

Problem	Potential Cause	Corrective Action
Fan Inoperative	Blown fuse or open circuit breaker	Replace fuse or reset circuit breaker and check amps
	Disconnect switch in "Off" position	Turn to "On" position
	Motor wired incorrectly	Check motor wiring to wiring diagram located on fan motor
	Broken fan belt	Replace belt
	Motor starter overloaded	Reset starter and check amps
Motor Overload	Fan rotating in the wrong direction	Be sure fan is rotating in the direction shown on rotation label
	Fan speed is too high	Reduce fan RPM
	Motor wired incorrectly	Check motor wiring to wiring diagram located on fan motor
	Overload in starter set too low	Set overload to motor FLA value
	Motor HP too low	Determine if HP is sufficient for job
	Duct static pressure lower than design	Reduce fan RPM
Insufficient Airflow	Fan rotating in the wrong direction	Be sure fan is rotating in the direction shown on rotation label
	Poor inlet/outlet conditions	There should be a straight clear duct at the inlet/outlet
	Damper not fully open	Inspect damper linkage and replace damper motor if needed
	Duct static pressure higher than design	Improve ductwork to eliminate or reduce duct losses
	Blower speed too low	Increase fan RPM. Do not overload motor
	Belt slippage	Adjust belt tension
Excessive Airflow	Blower speed too high	Reduce fan RPM
	Duct static pressure lower than design	Reduce fan RPM
Excessive Vibration and Noise	Misaligned pulleys	Align pulleys
	Damaged or unbalanced wheel	Replace wheel
	Fan is operating in the unstable region of the fan curve	Refer to performance curve for fan
	Bearings need lubrication or replacement	Lubricate or replace
	Fan speed is too high	Reduce fan RPM
	Belts too loose, worn or oily	Inspect and replace if needed

MAINTENANCE

To guarantee trouble free operation of this fan, the manufacturer suggests following these guidelines. Most problems associated with fan failures are directly related to poor service and maintenance.

Please record any maintenance or service performed on this fan in the documentation section located at the end of this manual.

WARNING: DO NOT ATTEMPT MAINTENANCE ON THE FAN UNTIL THE ELECTRICAL SUPPLY HAS BEEN COMPLETELY DISCONNECTED

General Maintenance

1. Fan discharge and approaches to ventilator should be kept clean and free from any obstruction.
2. Motors are normally permanently lubricated. Check bearings periodically. If they have grease fittings lubricate each season. Use caution when lubricating bearings, wipe the fittings clean, the unit should be rotated by hand while lubricating. Bearings should be lubricated every 2 months. The type of grease and the amount of grease can is shown below. **Caution: Bearings are sealed and over-greasing bearings can cause damage to the bearings. Do not grease until grease comes out of seals. Only add the appropriate amount of grease.**
3. All fasteners should be checked for tightness each time maintenance checks are performed prior to restarting unit.
4. Fans require very little attention when moving clean air. Occasionally oil and dust may accumulate causing imbalance. If the fan is installed in a corrosive or dirty atmosphere, periodically inspect and clean the wheel, inlet and other moving parts to ensure smooth and safe operation.

Bearing Grease Charge

Ball Bearings	
Shaft Size (Inches)	Grease Charge (Ounces)
1/2 to 3/4	0.03
7/8 to 1 3/16	0.10
1 1/4 to 1 1/2	0.15
1 11/16 to 1 15/16	0.20
2 to 2 7/16	0.30
2 1/2 to 2 15/16	0.50
3 to 3 7/16	0.85
3 1/2 to 4	1.50

Bearing Grease Type

Thickener	Lithium Complex
Oil	Petroleum
Thickness	NLGI 2
Operating Temperature	-20 F to 200 F Intermittent to 250 F

2 weeks after startup

1. Belt tension should be checked after the first 2 weeks of fan operation on belt drive fans. Belts tend to stretch and settle into pulleys after an initial start-up sequence. **Do not tension belts by changing the setting of the motor pulley**, this will change the fan speed and may damage the motor. To re-tension belts, turn the power to the fan motor OFF. Loosen the fasteners that hold the motor to the fan. Move the motor to the left or right to adjust the belt tension. Belt tension should be adjusted to allow 1/64" of deflection per inch of belt span. Exercise extreme care when adjusting V-belts as not to misalign pulleys. Any misalignment will cause a sharp reduction in belt life and produce squeaky noises. Over-tightening will cause excessive belt and bearing wear as well as noise. Too little tension will cause slippage at startup and uneven wear. **Whenever belts are removed or installed, never force belts over pulleys without loosening motor first to relieve belt tension.** When replacing belts, use the same type as supplied by the manufacturer. On units shipped with double groove pulleys, matched belts should always be used.
2. All fasteners should be checked for tightness each time maintenance checks are performed prior to restarting unit.

Every 3 months

1. Belt tension should be checked quarterly for belt drive fans. See instructions in the previous maintenance section. Over-tightening will cause excessive bearing wear and noise. Too little tension will cause slippage at startup and uneven wear.
2. Fans need to be cleaned quarterly, and more often in severe conditions.

Yearly

1. Inspect bearings for wear and deterioration. Replace/grease if necessary.
2. Inspect belt wear and replace torn or worn belts on belt drive fans.
3. Inspect bolts and set screws for tightness. Tighten as necessary.
4. Inspect motor for cleanliness. Clean exterior surfaces only. Remove dust and grease from the motor housing to ensure proper motor cooling. Remove dirt and grease from the wheel and housing to prevent imbalance and damage.

